

100 VJR



Working height 9.90 m
 Platform height 7.90 m
 Outreach 3.15 m



Platform capacity 200 kg (2 persons)
 External use 200 kg (1 person)
 Basket size 0.90*0.75 m



Overall length 2.82 m
 Overall width 0.99 m
 Overall height 1.99 m
 Ground clearance 10 cm
 Turning radius :
 Inside 0.49 m
 Outside 1.98 m



Turret rotation 350°
 Jib tilting 140°



Traction battery 24V/250Ah(C5)
 Integrated charger 24V/30Ah



Drivespeed 4 km/h
 Workingspeed 0.6 km/h



Gradeability 25%
 Max. slope accepted 2° or 3.5%



Weight 2650 kg

Standard equipment:

- Lifting brackets
- Horn
- Hour meter
- Battery charge indicator
- Emergency manual descent
- Wheels with non-marking tyres
- Integrated charger

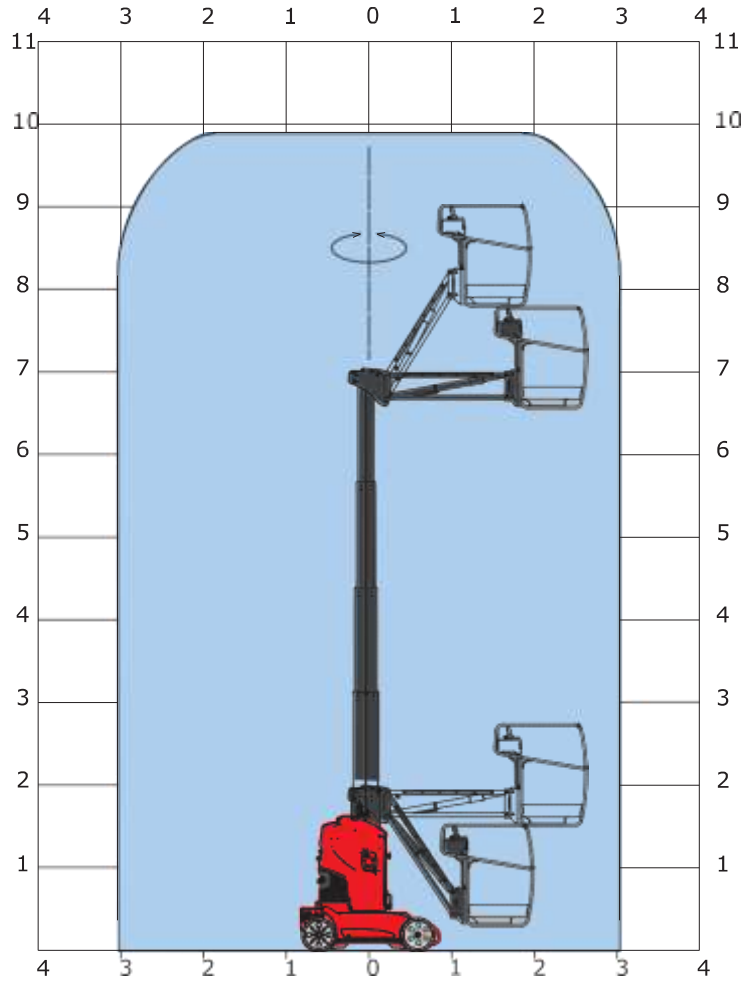

1

3

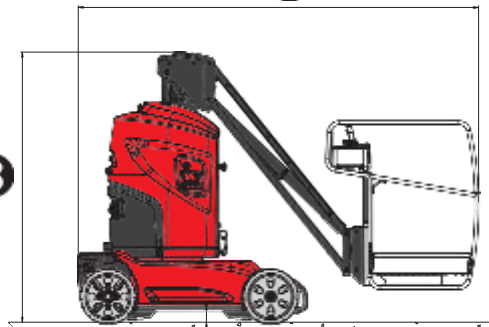

4

2

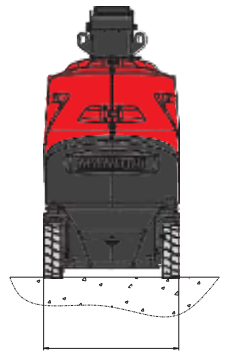

6

5

